

# Humidity Sensing Device for Soil, Atmosphere and Other Material with Temperature Intuit

Mr. Jawwad Khizar Patel<sup>1</sup>, Mr. Mohammed Abdul Moyeed<sup>2</sup>,  
Mr. Syed Ahmed Zayaanuddin<sup>3</sup>, Mr. Mohammed<sup>4</sup>, Mr. S.V Altaf<sup>5</sup>

<sup>1</sup> Social Innovator, Patentee, Entrepreneur, Student VII- Semester, Electronics and Communication Engineering, Lords Institute of Engineering & Technology, Hyderabad

<sup>2,3,4</sup> Student VII- Semester, Electronics and Communication Engineering, Lords Institute of Engineering & Technology,

<sup>5</sup> Associate Professor, Department of Electronics and Communication Engineering, Lords Institute of Engineering & Technology, Hyderabad

---

**Abstract:** In today's smart world where the man is rapidly proceeding towards development or advancement of various aspects, considering each and every point of possibility for the resulting outcome, we are forced as well as curious to measure quantities surrounding us. Therefore, we came up with an idea of significant relevance to measure and determine important quantities of physics namely temperature, humidity and physical moisture. The necessity of measurement of the above parameters in various fields like construction, industries, space and research compelled us to design this instrument with huge dedication. Its simultaneous measurement of all three quantities namely temperature, humidity and moisture makes it an outstanding instrument in the industry as well as households.

**Keywords:** A complete humidity sensing device for atmosphere, soil and other material using 8051 microcontroller and also detect moisture and temperature.

---



Device is a fabricated piece of circuitry (Integrated circuit), designed to provide us with an accurate extent of temperature, humidity and physical moisture of Atmosphere, soil and other material.

The information provided by our device comes in handy for almost every stream when it comes to precise construction and abbreviation of data.

## I. INTRODUCTION

### A. Embedded System in Hygrometer:

Modern embedded systems are often based on microcontrollers (i.e. CPUs with integrated memory or peripheral interfaces), but ordinary microprocessors (using external chips. An embedded system is a computer system with a dedicated function within a larger mechanical or electrical system, often with real-time computing constraints. It is embedded as part of a complete device often including hardware and mechanical parts. Embedded systems control many devices in common use today. Ninety-eight percent of all microprocessors are manufactured as components of embedded systems.

Since the embedded system is dedicated to specific tasks, design engineers can optimize it to reduce the size and cost of the product and increase the reliability and performance. Some embedded systems are mass-produced, benefiting from economies of scale.

### B. User Interface:



The UI of our device is as simple as it could be which is called as user centered, simplicity is the key to this project. The sequence of our interface represents various screens which represent introductions and live measurement data. A power switch with an LED indicator is provided on the dashboard of the system for easy operation and indication.

## II. BLOCK DIAGRAM

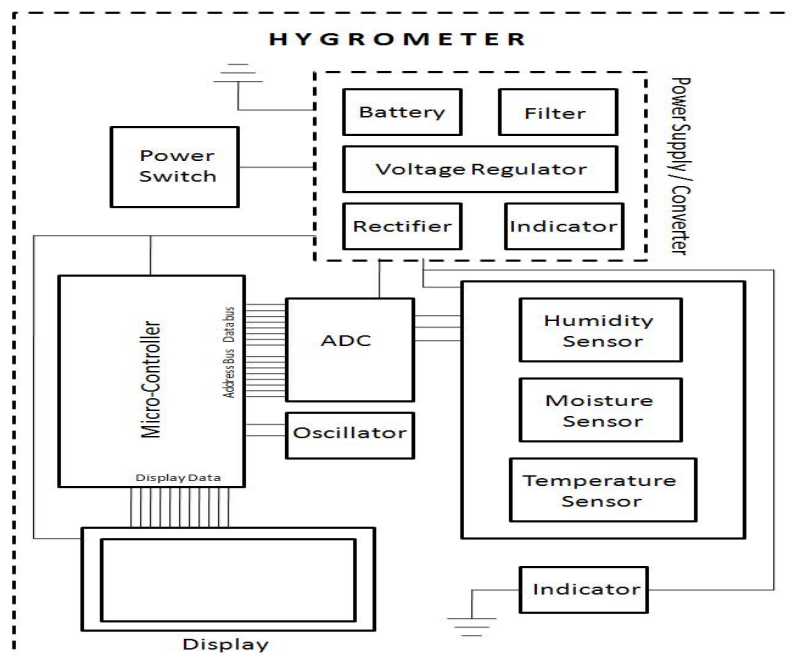

The key component in the system is the 8051 micro-controller interfaced to three sensors using an Analog to digital converter (0808). The processed data is sent to the 20x4 LCD display connected to the port-0 of the micro-controller.

Three sensors i.e. temperature (LM35), humidity (MQ3) and moisture (LM741MS) are not present on the same board. This means that they are interfaced to the ADC.

The power-supply and regulation unit consists of rectifier, voltage regulator, battery, filter and indicator. This power-supply is connected to various integral parts at a regulated +5v whereas the ground is commonly connected throughout the circuit. The micro-controller consists of a crystal oscillator at port18-19 input for an efficient oscillation frequency of 11.0592 MHz in AT89S52.

### III. SCHEMATICS

#### 3.1 Schematics Overall:

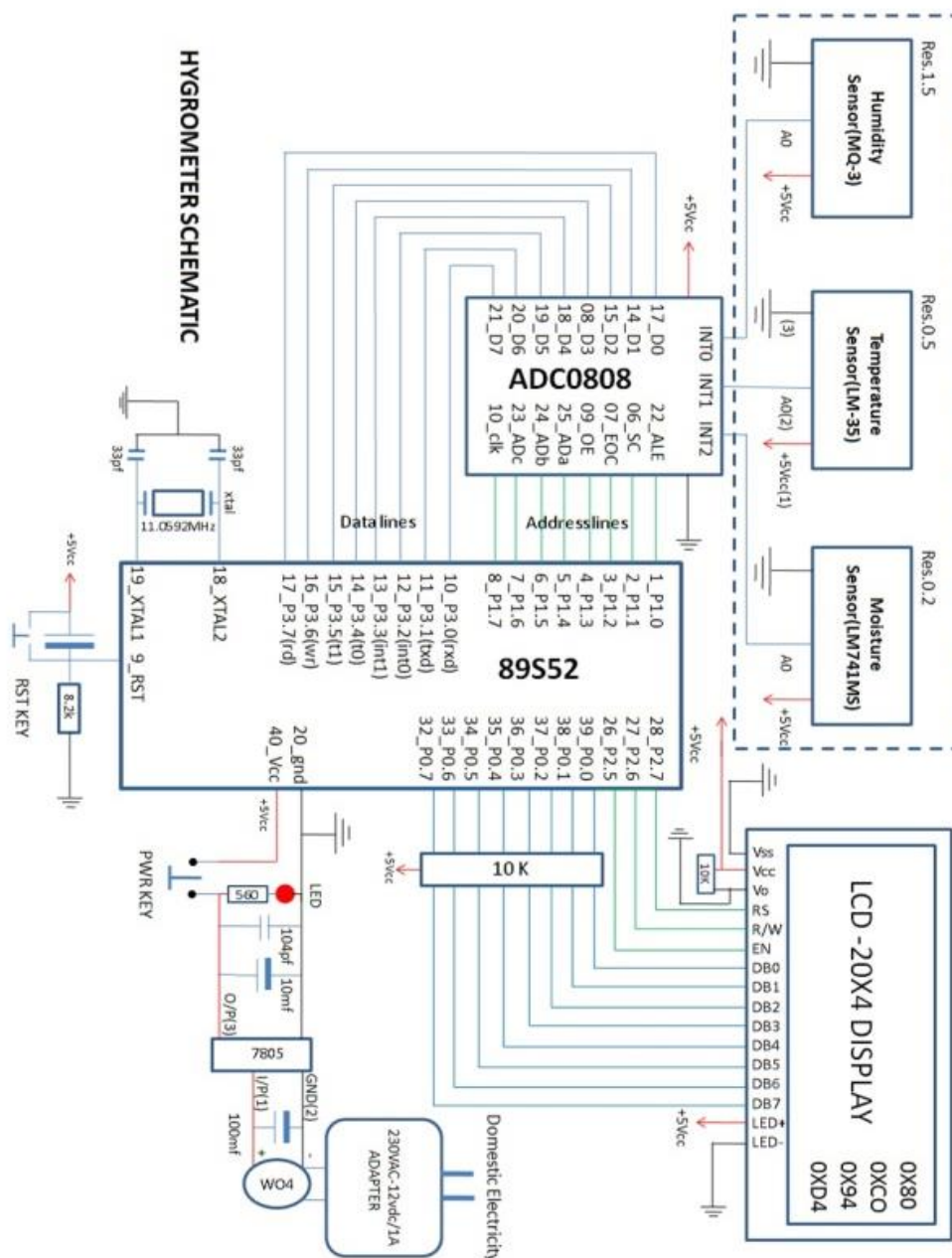

### 3.1.1 Schematic Description:

The micro controller is key device used for data representation and processing. IT consist of four port in which the port 0 is connected to the data lines of 20x4 LCD small display.

The port 2 has rest of the essential pins of LCD, namely RS,RW and enable. Port 1 is connected to the address lines of ADC and port 3is connected to data lines.

The power-supply and regulation unit consists of rectifier, voltage regulator, battery, filter and indicator. This power-supply is connected to various integral parts at a regulated +5v whereas the ground is commonly connected throughout the circuit.

The micro-controller consists of a crystal oscillator at port18-19 input for an efficient oscillation frequency of 11.0592 MHz in AT89S52.

## IV. FLOWCHART

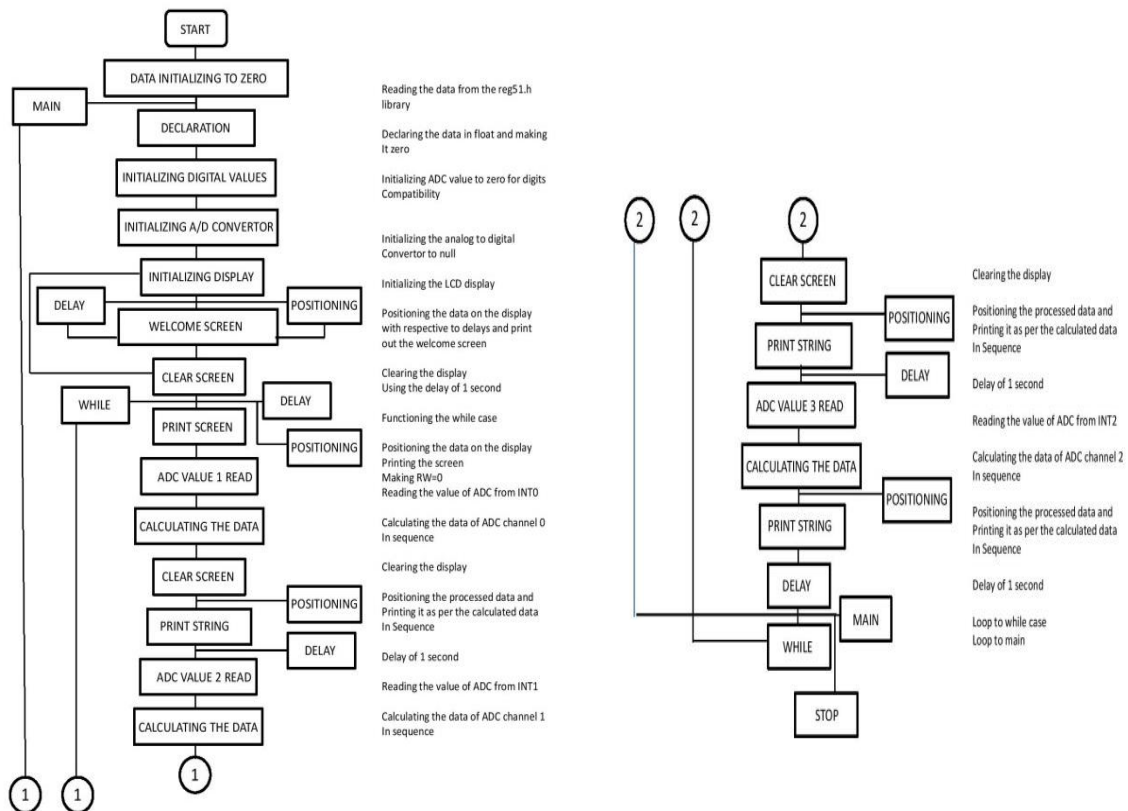

### 4.1 Applications:

1. Measurement of temperature, humidity and physical moisture simultaneously in a single device.
2. A 14x8 inch apparatus makes it portable.
3. Very Safe equipment with no hazardous or 4. Toxic emission
4. Significantly low power consumption, even with all the simultaneous measurement
5. Simply UI for ease of access to the information.

### 4.2 Uses:

1. Vast industrial usage in diverse conditions.
2. Metrology demands on accurate measure of all quantities

3. All essential processes including construction require the instrument.
4. Aerospace research and development services have a major use of it.
5. Health Care and Medicine find a no. of uses making it one of the important instruments in the field
6. The weather forecasting and prediction are initially based on our specified measuring quantities , so the device is base concerned

## V. RESULTS

Therefore, we find the resultant measurement of three very important quantities which are temperature, humidity and moisture are simultaneously determined. Successfully knowing all the accurate values makes the project most useful in our day-to-day life.

## VI. CONCLUSION

The proposed instrument has been used to determine temperature, humidity and physical moisture which can be utilized in almost every field. This electronic device measures all the three quantities simultaneously in real time to carry out different processes and required results can be achieved with high portability factor as the apparatus is considerably compact. A very simple user-interface makes sure the ease in determination of atmospheric quantities.

## VII. FUTURE WORK

Using the device as a framework, the technical aspects can be enhanced by integrating various sensors for additional functionality such as accelerometer and different measuring capabilities. Further, the product portability can be extremely improved with inclusion of nano-technology i.e. pocket friendly applications can be performed. The accuracy and efficiency of the product can significantly be increased by developing the hardware enclosure and processing capabilities.

## ACKNOWLEDGEMENT

The efforts put into the project to build up the resultant electronic device has been tremendous as the assignment constitutes a major part of dedication of the project members and the associate professor (**Mr S.V. Altaf**). We appreciate all the hard work of the experts contributing towards development of various atmospheric measurement systems and also **Mr. S.V Altaf** for guiding us to build such an important product.

## RELATED WORK

[1] Akash Jain, Suraj Kudre, Mahesh Giri

This paper proposes Monitoring of environmental factors is very important over the last few decades. In particular, monitoring agricultural environments for various factors such as temperature, moisture, humidity along with other factors can be of more significance. A traditional approach to measuring these factors in an agricultural environment meant individuals manually taking measurements and checking them at various times. In this paper remote monitoring systems using wireless protocols used by different researchers for betterment of agricultural yield with best possible technologies is discussed. This is followed by proposed introductory model for agricultural monitoring with wireless protocol implemented using field programmable gate array (FPGA).

[2] Meghana. R. Kanitkar, Dr. J. S. Awati

This paper proposes The places such as weather forecasting system, nuclear radiation measurement, greenhouses, agro-automation systems require real-time monitoring of environmental parameters like temperature and humidity. So a low-cost, low-power temperature and humidity sensor interfacing with embedded systems using PIC microcontroller and PLC is designed. The paper is analyzing the operating mechanism of DHT11 temperature and humidity combined sensor; where it features temperature and humidity sensor complex with calibrated digital signal output. The DHT11 sensor interfacing with controller is programmed, then the temperature and humidity acquisition program porting to embedded platform. Meanwhile, the data through human machine interface is intuitive feedback to the user. The system has good scalability and stability, and has good application prospects in climate change measurement.

**[3] Jingbo Tong**

This paper proposes Humidity measurement has been increasingly important in many industries and process control applications. This thesis research focus mainly on humidity sensor calibration and characterization. The humidity sensor instrumentation is briefly described. The testing infrastructure was designed for sensor data acquisition, in order to compensate the humidity sensor's temperature coefficient, temperature chambers using Peltier elements are used to achieve easy-controllable stable temperatures. The sensor characterization falls into a multivariate interpolation problem. Neuron networks is tried for non linear data fitting, but in the circumstance of limited training data, an innovative algorithm was developed to utilize shape preserving polynomials in multiple planes in this kind of multivariate interpolation problems.

**[4] Aakanksha Pimpalgaonkar, Mansi Jha, Nikita Shukla, Kajol Asthana**

The objective is to design and implement an automated Temperature control system using embedded system design in order to control the temperature of a system. As such, it is vital that those in engineering fields understand the technologies associate with this area. My paper will include the design and construction of a microcontroller - based automated temperature control system along with a temperature display using LCD. A working system will ultimately be demonstrated to validate the design. The system made is only a prototype. A larger system can be made using this prototype as a model.

**REFERENCES**

- [1] Akash Jain, Suraj Kudre, Mahesh Giri A REVIEW ON SMART SENSORS BASED MONITORING SYSTEM FOR AGRICULTURE, e-ISSN 2277-2685, p-ISSN 2320-976 IJESR/May 2014/ Vol-4/Issue-5/352-355 Akash Jain et al./ International Journal of Engineering & Science Research
- [2] Meghana. R. Kanitkar, Dr. J. S. Awati DESIGNING OF TEMPERATURE & HUMIDITY MONITORING EMBEDDED SYSTEMS INTERNATIONAL CONFERENCE ON COMPUTING, COMMUNICATION AND ENERGY SYSTEMS (ICCCES-16) In Association with IET, UK & Sponsored by TEQIP-II 29th -30th, Jan. 2016
- [3] Jingbo Tong MEASUREMENT AND MODELING OF HUMIDITY SENSORS University of Kentucky UKnowledge
- [4] Aakanksha Pimpalgaonkar, Mansi Jha, Nikita Shukla, Kajol Asthana International Journal of Scientific and Research Publications, Volume 3, Issue 12, December 2013 1 ISSN 2250-3153

**AUTHORS PROFILE**

**Mr. Jawwad Khizar Patel** Pursuing B-Tech in Electronics and Communication Engineering from Lords Institute of Engineering and Technology, Hyderabad, being an inventor himself holding 2 patents in the fields of Electronics and publish many national and international research paper, He Got featured in over 200 media channels in about 50 countries across different streams –print, radio, TV and Web He owns his Personal Lab and a Website.



**Mr. Mohammed Abdul Moyeed** Pursuing B-Tech in Electronics and Communication Engineering from Lords Institute of Engineering and Technology, Hyderabad.



**Mr. Syed Ahmed Zayaanuddin** Pursuing B-Tech in Electronics and Communication Engineering from Lords Institute of Engineering and Technology, Hyderabad.



**Mr. Mohammed** Pursuing B-Tech in Electronics and Communication Engineering from Lords Institute of Engineering and Technology, Hyderabad.



**Mr. S.V Altaf** Assoc professor in ECE department at Lords Institute of Engineering and Technology has 27 years of Industrial experience in the field of Embedded Systems along with 10 years of teaching experience in Micro-Processors , Micro-Controllers and its applications. Also published Micro-Processors and Micro Controllers (MP-MC), Micro-Processor and Interfacing (MPI) books.